



**PRAMAC** small wind generators are suitable for a variety of residential homes, tourist resorts, streetlights and agricultural structure applications. They effectively lower energy cost and reduce the impact on the environment by combining efficiency and design.

This is a smart way to convert wind energy into electricity and satisfy everyday energy needs through an extremely efficient and, at the same time, aesthetically appealing and noiseless tool.

**PRAMAC** Wind Generators are **Vertical Axis Turbines** (Darrieus H-shape type), since:

- **noiseless** (unlike the **Horizontal Axis Wind Turbines**)
- the **function** is **independent from wind direction** (unlike the HAWT)
- this choice gives **more freedom** to S'ARCK' design.

Moreover they are very **small in size**.

REVOLUTION  
STARTS  
AT HOME

*PRAMAC wind turbines  
are silent.*



*The most direct and “smart” way to directly operate for a better and cleaner world, free from “oil slavery”.*



- **Useful tool**  
(from a technical point of view, it is efficient and state-of-the-art; it has a well defined function)
- **Economically profitable**  
(a very important and timely factor in the consumption crisis affecting us today)
- **Competitively priced with a variety of sizes to select from**

**CARBON FOOTPRINT reduction.**

*A personal contribution to the planet.  
A symbol of my “ecological conscience”.  
A “beautiful” object to furnish my home.  
A S+ARCK’s model to be shown.*

The first two models are available from **PRAMAC**:

- *a **Twin Blades** model: WT400W*
- *a **Triple Blades** model: WT1kW*









### Rotor

Darrieus rotor type	2-blades
Power output at wind speed 10 m/s	110W
Power output at wind speed 15 m/s	400W
Cut-in wind speed	3 m/s
Cut-off wind speed	15 m/s
Diameter x height	0,9 m x 0,9 m
Sweep area	0,81 m <sup>2</sup>
Rotor weight (alternator included)	26 Kg
Braking system	passive

### Alternator

Type	Permanent magnets
Phase number	3

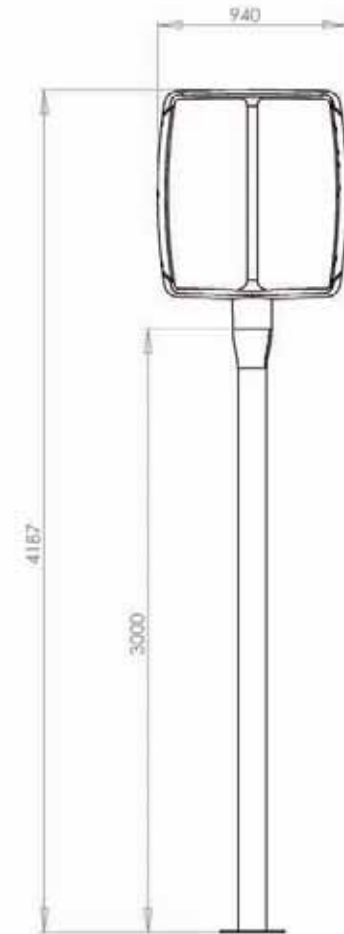
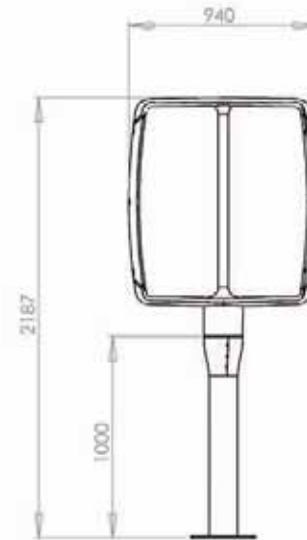
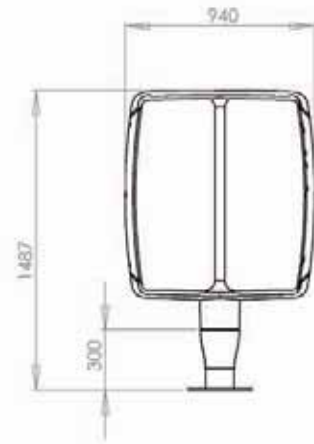

## Twin Blades WT400W

Transparency, an idea created in the air.

A complete innovative design that utilizes less weight and size for superior performance.

### Derating

At high temperatures and/or high-altitude installations, the air density drops and the turbine may generate less than rated power. For high-altitude installation, please estimate approximate 1% loss of power for every 100m above sea level.

The wind generator has been designed in compliance with IEC 61400-2, class IV.

The values indicated below refer to the following conditions:  
 Temperature: -20/+50°C  
 Humidity: <95%  
 Air density: 1.225 kg/m<sup>3</sup>  
 Solar radiation: 1000 W/m<sup>2</sup>

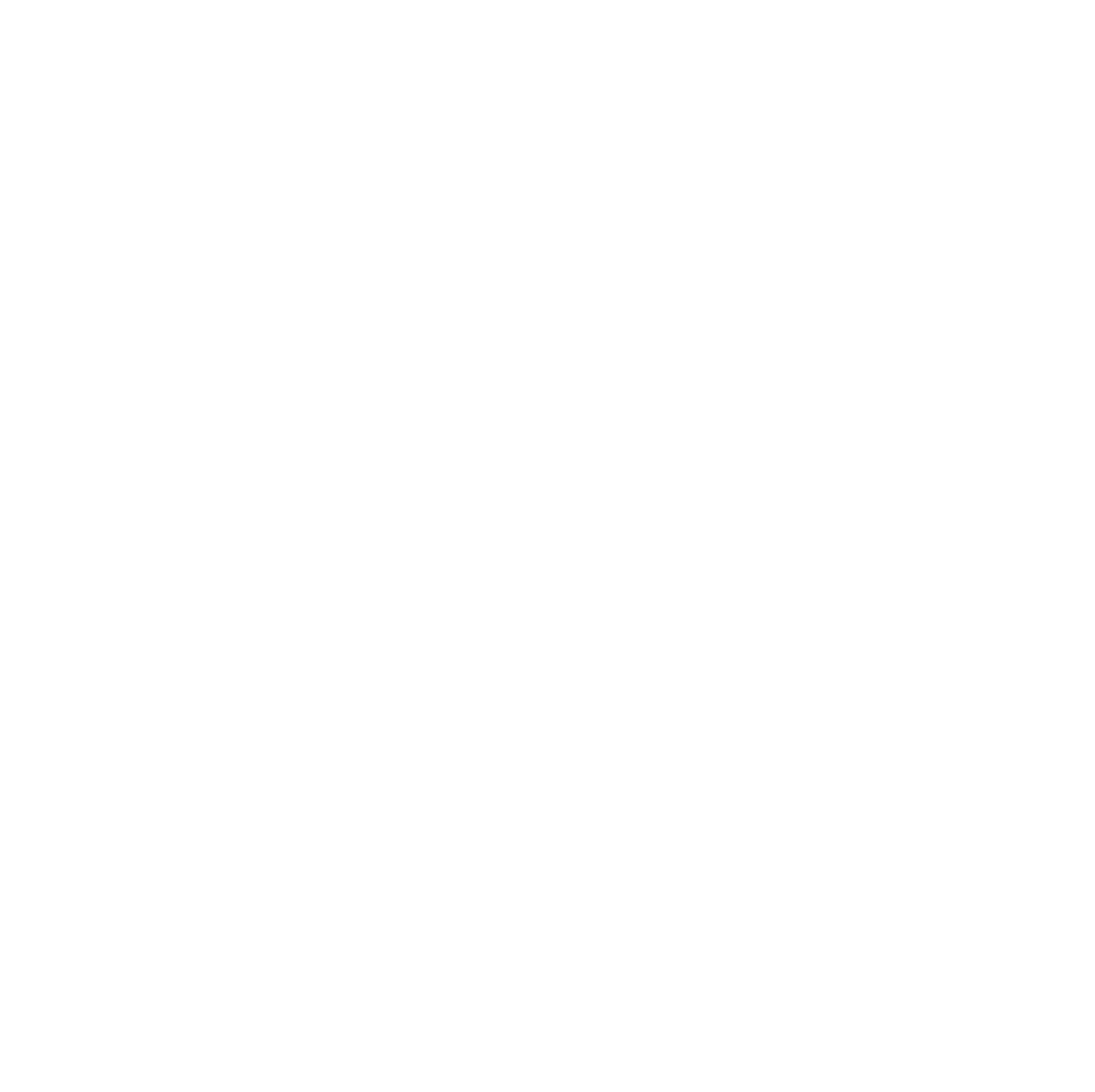



# Twin Blades WT400W

Tools and optionals.

## Product

- 1.**  
**Rotor and Alternator**  
(with permanent magnets)



## Accessories

- 2.** **Standing Pole 0,3 m** (11,5 Kg)
- 3.** **Standing Pole 1 m** (17 Kg)
- 4.** **Standing Pole 3 m** (56,5 Kg)
- 5.** **WIND BOX 400 IP66 GC**  
DC Interface and safety brake
- 6.** **Inverter Windy Boy 1100 SMA**  
Dedicated device for grid connection
- 7.** **Diversion Load**
- 8.** **Braking Resistance**
- 9.** **Passive Braking Block+Protection**

## Optionals

- 10.** **Foundation Kit**

## Colours

Transparent

### Pole Colour

- Warm Gray 2 U



2  
3  
4





5



6



7

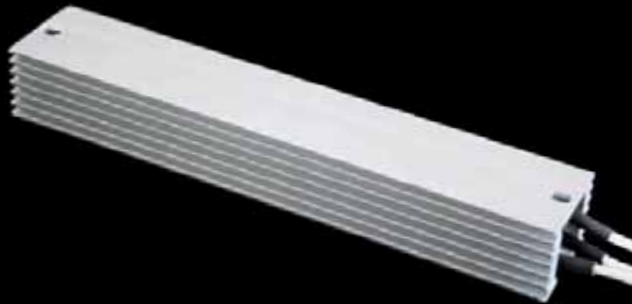

8

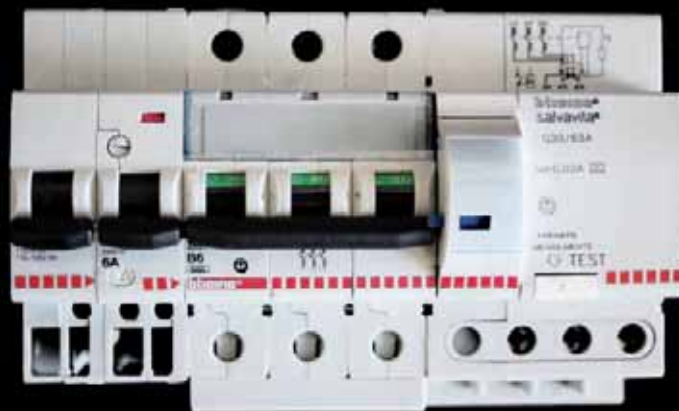

9



10



## Rotor

Darrieus rotor type	3-blades
Power output at wind speed 10 m/s	250W
Power output at wind speed 15 m/s	1000W
Cut-in wind speed	3 m/s
Cut-off wind speed	15 m/s
Diameter x height	1,45 m x 1,45 m
Sweep area	2,10 m <sup>2</sup>
Rotor weight (alternator included)	65 Kg
Braking system	passive

Acoustic pression LpA from 4 mt	52 dB(A)
Acoustic power LWA	72 dB(A)

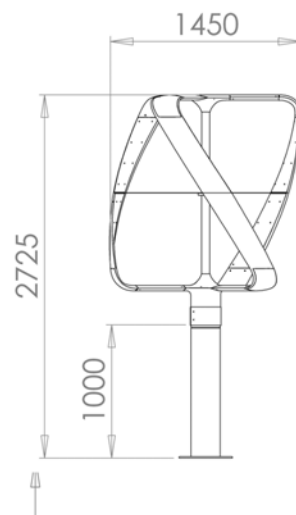

## Alternator

Type	Permanent magnets
Phase number	3

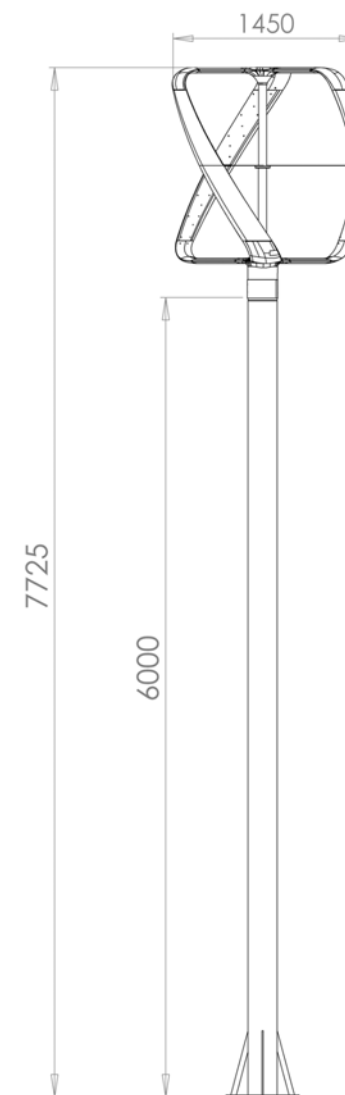
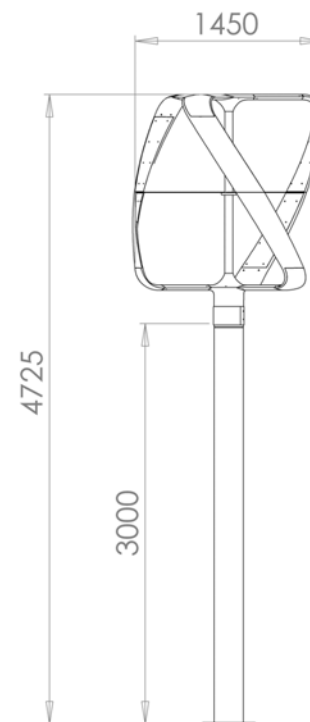

## Triple Blades WT1KW

The air round and round and round.

A complete innovative design that utilizes less weight and size for superior performance.

### Derating

At high temperatures and/or high-altitude installations, the air density drops and the turbine may generate less than rated power. For high-altitude installation, please estimate approximate 1% loss of power for every 100m above sea level.

The wind generator has been designed in compliance with IEC 61400-2, class IV.

The values indicated below refer to the following conditions:  
 Temperature: -20/+50°C  
 Humidity: <95%  
 Air density: 1.225 kg/m<sup>3</sup>  
 Solar radiation: 1000 W/m<sup>2</sup>

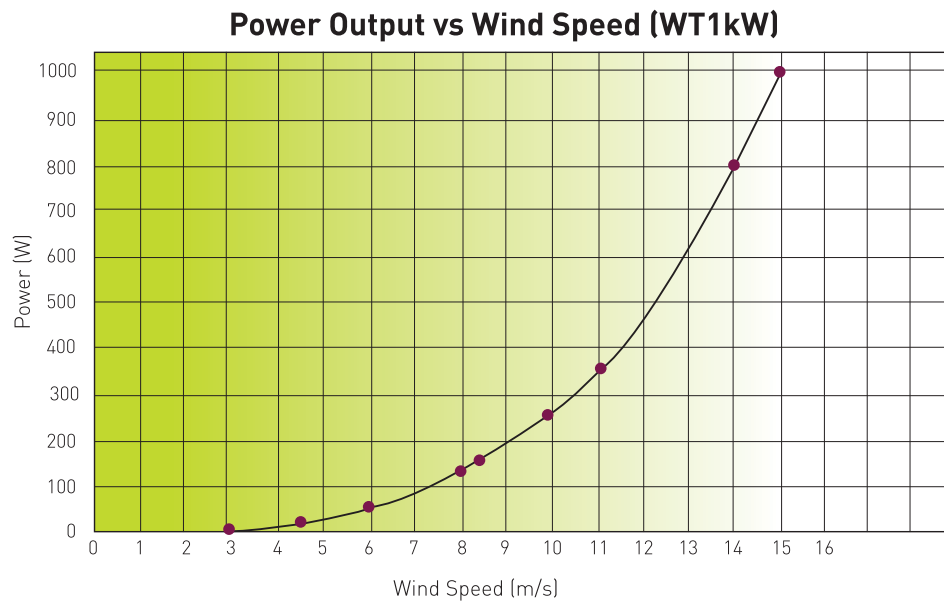

# Triple Blades WT1KW

Tools and optionals.

## Product

- 1.**  
*Rotor and alternator*  
*(with permanent magnets)*



## Accessories

- 2.** *Standing Pole 1 m (25 Kg)*  
**3.** *Standing Pole 3 m (88 Kg)*  
**4.** *Standing Pole 6 m (189 Kg)*
- 5.** *WIND BOX 1000 IP66 GC*  
*DC Interface and safety brake*
- 6.** *Inverter Windy Boy 1100 SMA*  
*Dedicated device for grid connection*
- 7.** *Diversion Load*
- 8.** *Braking Resistance*
- 9.** *Passive Braking Block+Protection*

## Optionals

- 10.** *Foundation Kit*  
**11.** *FLAT ROOF support kit*

## Colours

- *Warm Gray 2 U*
- *Warm Gray 11 C*

2  
3  
4

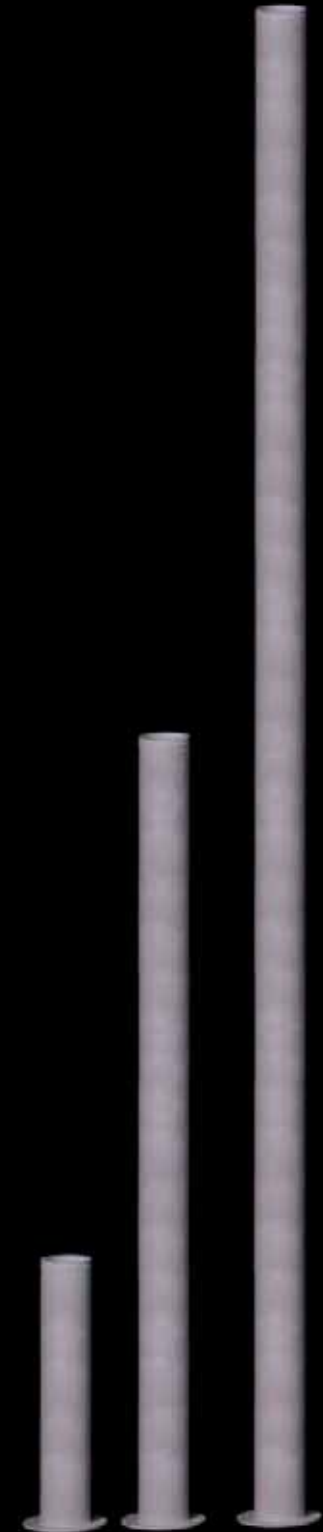



5



6



7



8

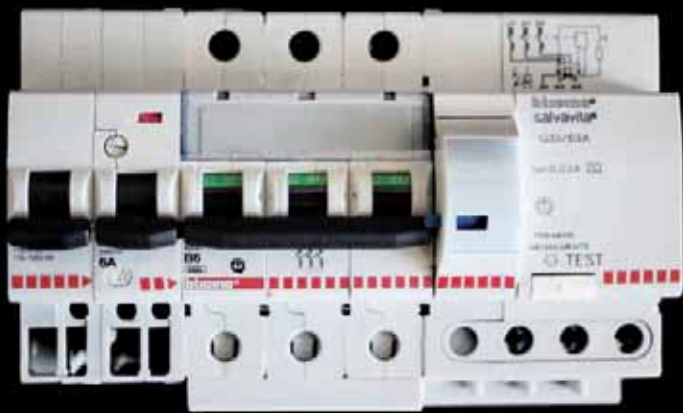

9



10



11





*PRAMAC's wind turbines  
are independent  
of wind direction.*

